

ELECTRIC TILTING BRATT PANS

Item:

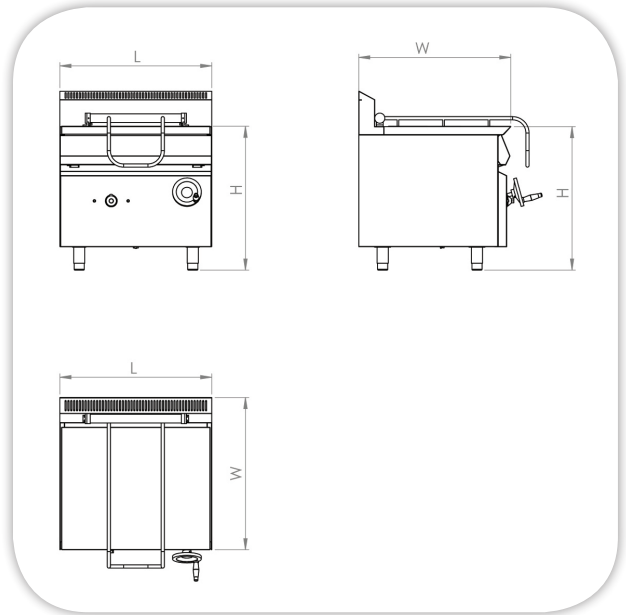
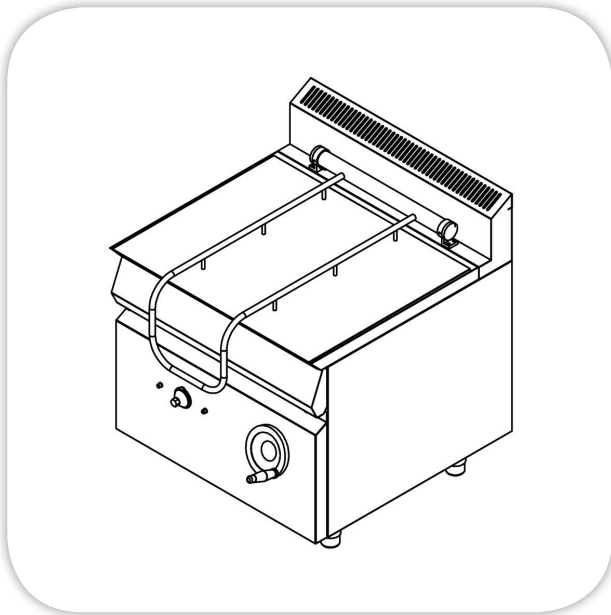

SPECIFICATIONS: (Heavy Duty)

Body: Stainless steel (304) construction.

Pan: Stainless steel (304) construction, base (8) mm thickness, pan tilting by hand wheel, Lid open up 90°, thermal insulation all over the body.

Control: thermostatically controlled.

Electric source: 380V/3PH/50Hz

Electric accessories: High quality, heavy duty EGO (Germany)

Legs: (4) legs, stainless steel, 60 mm diameter, with Adjustable leveling feets.

TECHNICAL DATA:

MODEL	FRYING Capacity (lt)	Dimensions (mm)			Electric Power (kW)	Net Weight (Kg)
		L	W	H		
METP01-11-80 Electric Tilting bratt Pan-80 liter	80	900	900	900	12.0	
METP01-11-120 Electric Tilting bratt Pan-120 liter	120	1200	900	900	18.0	

Masria, In Line with its policy to continually improve its quality, reserves the right to change specs without notice.

+202 44812326/8

masria@masria.com

masriagroup

+201 001609002/10

www.masria.com

masriagr

